

# TM 11-6130-236-35

DEPARTMENT OF THE ARMY TECHNICAL MANUAL

---

## DS, GS, AND DEPOT MAINTENANCE MANUAL CHARGER, BATTERY PP-1451/G

(NSN 6130-00-985-8157)

This copy is a reprint which includes current pages from Change, The title was changed as shown above by Change 1.

---

HEADQUARTERS, DEPARTMENT OF THE ARMY  
27 MAY 1966

DS, GS, AND DEPOT MAINTENANCE MANUAL

CHARGER, BATTERY PP-1451/G  
 (NSN 6130-00-985-8157)

**REPORTING OF ERRORS**

You can help improve this manual by calling attention to errors and recommending improvements and stating your reasons for the recommendations. Your letter or DA Form 2028 (Recommended Changes to Publications and Blank Forms) should be mailed direct to Commander, US Army Communications and Electronics Materiel Readiness Command, ATTN: DRSEL-MA-Q Fort Monmouth, NJ 07703. A reply will be furnished direct to you.

Paragraph

CHAPTER 1.	FUNCTIONING OF EQUIPMENT		
	Scope . . . . .	1-1	1-1
	Index of equipment publications . . . . .	1-2	1-1
	Block diagram analysis . . . . .	1-3	1-1
	Circuit analysis . . . . .	1-4	1-2
2.	TROUBLESHOOTING		
	General instructions . . . . .	2-1	2-1
	Organization of troubleshooting procedures . . . . .	2-2	2-1
	Test equipment required . . . . .	2-3	2-1
	Localizing troubles . . . . .	2-4	2-2
	Tests for open fuses . . . . .	2-5	2-3
	Additional troubleshooting data . . . . .	2-6	2-3
	General parts replacement techniques . . . . .	2-7	2-4
	Adjustment of variable resistors R1, R2, R3, and R4 . . . . .	2-8	2-4
3.	GENERAL SUPPORT TESTING PROCEDURES		
	General . . . . .	3-1	3-1
	Test equipment, tools, and materials . . . . .	3-2	3-1
	Physical tests and inspections . . . . .	3-3	3-3
	Twenty-eight volt output, regulation, ripple, and efficiency test . . . . .	3-4	3-5
	Two hundred and thirty volts, 60-cps, input power test.....	3-5	3-7
	One hundred and fifteen volts, 400-cps, input power test . . . . .	3-6	3-9
	Two hundred and thirty volts, 400-cps, input power test.....	3-7	3-11
	Test data summary . . . . .	3-8	3-12
4.	DEPOT OVERHAUL STANDARDS		
	Applicability of depot overhaul standards . . . . .	4-1	4-1
	Applicable references . . . . .	4-2	4-1
	Test facilities required . . . . .	4-3	4-1
	Tests . . . . .	4-4	4-1
APPENDIX	REFERENCES . . . . .		A-1

\*This manual supersedes TM 11-6130-236-15, October 1965.

## CHAPTER 1

### FUNCTIONING OF EQUIPMENT

---

#### 1-1 Scope

*a.* This manual contains direct support, general support, and depot maintenance instructions for Charger, Battery PP-1451/G (battery charger). It includes instructions appropriate for troubleshooting, testing, and repairing the equipment. It also lists tools, materials, and test equipment required for maintenance. Functional analysis of the equipment is covered in this chapter.

*b.* The complete technical manual for this equipment includes TM 11-6130-236-12.

Note. For applicable forms and records, see paragraph 1-3, TM 11-6130-236-12.

#### 1-2. Index of Equipment Publications

Refer to the latest issue of DA Pam 310-4 to determine whether there are new editions, changes, or additional publications pertaining to the equipment. DA Pam 310-4 is an index of current technical manuals, technical bulletins, supply manuals (types 7, 8, and 9), supply bulletins, lubrication orders, and modification work orders that are available through publications supply channels. The index lists the individual parts (-10, -20, -35P, etc.) and the latest changes to and revisions of each equipment publication.

#### 1-3 Block Diagram Analysis (fig. 1-1)

*a.* Input power of 115 volts alternating current (at) or 230 volts ac at 50 cycles per second (cps), 60 cps, or 400 cps is applied to circuit breaker CB1. With CB1 at the ON position, input power is applied through the appropriate input voltage selector linkage to transformer T1.

*b.* The input voltage selector consists of two shorting links. With the linkage in the 115 ac position, the two primary windings of transformer T1 are connected in parallel. With the linkage in the 230 ac position, the two primary windings of transformer T1 are connected in series.

*c.* Blower fan motor B1 (rated at 115 volts ac, single phase) is connected across one of the primary windings of T1 to insure 115-volt ac supply regardless of input voltage linkage connections.

*d.* The input frequency selector linkage consists of four shorting links. These links are used to connect for either 50/60 or 400 cps. All four links must be in the same position (either 50/60 or 400). There is one link for each of the four magnetic amplifiers (L1 through L4).

*e.* Each of two transformer T1 secondary windings is connected to a full-wave bridge rectifier, with the gate windings of two magnetic amplifiers forming a part of each bridge in conjunction with two of the four diode rectifiers.

*f.* The two magnetic amplifiers are used in push-pull as control for each full-wave rectifier. The first and second control windings of each magnetic amplifier are used in conjunction with regulating diodes as part of the regulation circuit. Changes in current flow in the first and second control windings cause proportional impedance changes in the gate windings to control the rectifier output voltage.

*g.* The output of each bridge rectifier appears across filter networks consisting of half a dual winding choke, L5 (sections A and B), and five filter capacitors. Protective fuses are used to prevent equipment damage due to filter capacitor failure (shorting).

*h.* The outputs of the filter networks are connected to bleeder resistors. The bleeder resistors are connected to switch 28V-S2-56V. With switch 28V-S2-56V set to the 28V position, the bleeder resistors are connected in parallel. With switch 28V-S2-56V set to the 56V position, the bleeder resistor are connected in series.

*i.* In the bleeder resistor circuit, VOLTAGE ADJUST control R8 is used to feed back a control current through a Zener diode to the first control winding of the magnetic amplifiers. A fuse is used to prevent excessive current through the Zener diode. Variation of the control current through the first control windings will cause a proportional change in the output voltage.

*j.* The outputs of each filter network are fed to the input of a contractor. The coils of the contractors are energized by the output of full-wave bridge rectifier CR10 through CR13 in a third secondary winding of transformer T1.

*k.* When the contractors are energized, the filtered output of each rectifier is connected to the output voltage selector linkage. With the linkage set to 28V, the two outputs are connected in parallel. With the linkage set to 56V, the two outputs are connected in series. The output voltage selector linkage consists of two shorting links.

*l.* The positive output is coupled through OUTPUT CURRENT meter M1 shunt to the + OUTPUT terminal on the front panel. (PRESS TO READ switch S3 must be actuated to determine the current output of the battery charger.)

*m.* OUTPUT VOLTAGE meter M2 is connected across the contacts of the output voltage selector linkage so that the output voltage may be monitored.

*n.* Separate regulating circuits are provided for voltage variations due to load. With NORMAL CHARGE switch S1 set to NORMAL, the regulating circuit detect changes in the voltage drop across the filter choke. These voltage changes cause current variations in a control winding to maintain the selected voltage at a maximum output current of 50 amperes for 28-volt operation, or 25 amperes for 28-volt operation, or 25 amperes for 56-volt operation. With NORMAL-CHARGE switch S1 set to CHARGE, the maximum current output is between 70 and 80 amperes for 28-volt operation, or between 35 and 40 amperes for 56-volt operation.

#### 1-4. Circuit Analysis (fig. 4-4)

*a. Power Supply.* Charger, Battery PP-1451/G can be operated from either a 115-volt or 230-volt ac source, at 50, 60, or 400 cps. The input power is connected to pins A and B of J1 and applied through dual power switch and circuit breaker CB1A and CB1B to the two primaries of power transformer T1. Power switch and circuit breaker CB1 is the power switch for the equipment and, in addition, provides overload protection. The two primaries of T1 are interconnected through links at T1A and T1B to enable parallel connection (115 volts ac) or series connection (230 volts at). Blower fan motor B1 is connected across pins 3 and 4 of the primary of T1 and provides cooling for the interior areas of the battery charger. Capacitor C1 permits B1 to be self-starting. Capacitors C18, C19, C20, and C21 are used to suppress radiofrequencies that may be generated within the power supply. Terminal C on J1 provides a common (ground) connection for the input power.

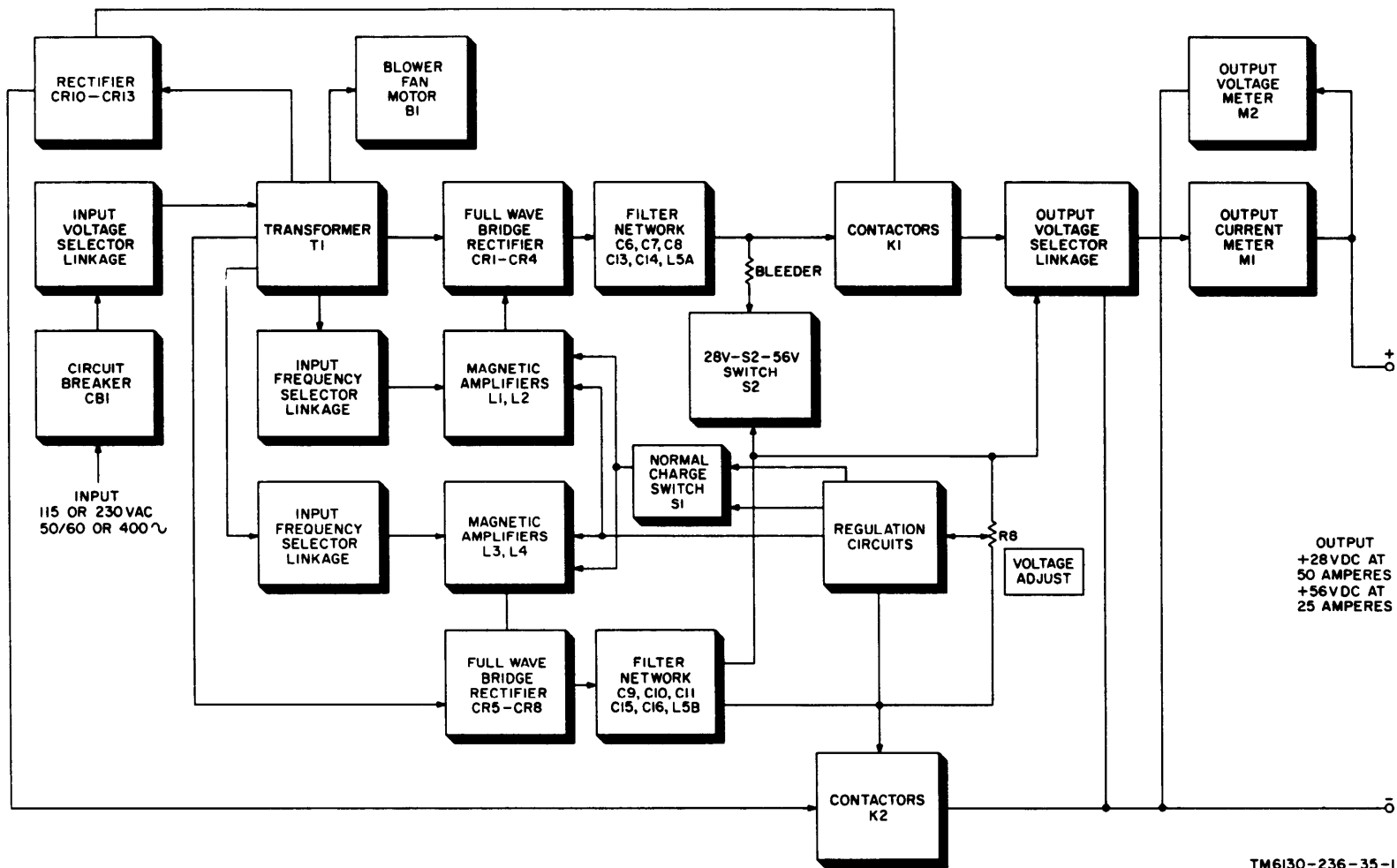

TM6130-236-35-1

Figure 1-1. Block diagram

115-volt operation to provide 60 amperes of overload protection. For 230-volt input power, the links of T1A and T1B connect both primary windings of T1 in series. Both 30-ampere circuit breakers are now placed to provide 30 amperes of overload protection.

- (2) The ac output of T1 is stepped down to approximately 42 volts ac. The ac voltage at terminals 5 and 6 of T1 is applied to a full-wave bridge rectifier consisting of CR1 through CR4 and toroid gate windings of magnetic amplifiers L1 and L2. The ac voltage at terminals 7 and 8 of T1 is applied to a second full-wave bridge rectifier consisting of CR5 through CR8 and the gate windings of magnetic amplifiers L3 and L4. A third winding of T1, terminals 9 and 10, provide 30 volts ac to full-wave bridge rectifier CR10 through CR13.
- (3) The pulsating dc voltage output of rectifiers CR1 through CR4 is applied to a filter network consisting of choke L5A and filter capacitors C6, C7, C8, C13, and C14. The output of CR5 through CR8 is applied to a filter network consisting of choke L5B and filter capacitors C9, C10, C11, C15, and C16. The output of CR10 through CR13 does not require filtering. Fuses F1 through F4 and F6 through F9 (30-ampere rating) are used to prevent overload damage to equipment.
- (4) The filtered dc output of CR1 through CR4 is connected to a bleeder resistor network consisting of R5, R6, and R7, to a contact of switch 28V-S2-56V and to contacts of relay K1. The filtered dc output of CR5 through CR8 is connected to bleeder resistor network R8, R9, and R10, to a second contact switch 28V-S2-56V and to contacts of relay K2. The output of CR10 through CR13 is applied to indicator lamp DS1 and to the coils of K1 and K2.

- (5) The two filtered dc outputs of the full-wave bridge rectifiers can be connected in series (56-volt dc operation) or in parallel (28-volt dc operation). This is accomplished by positioning both 28 DC OUTPUT 56 links to the correct 28 or 56 position. The 28V-S2-56V switch must be set to agree with the position selected for the 28 DC OUTPUT 56 links. With the 28V-S2-56V switch set to 56V, all bleeder resistors are connected in series. With 28V-S2-56V switch set to 28V, bleeder resistors R5, R6, and R7 are connected in parallel with bleeder resistor R8, R9, and R10.

- (6) The voltage output of the battery charger is indicated on OUTPUT VOLTAGE meter M2 with a range of 0 to 75 volts dc. The current output is indicated on OUTPUT CURRENT meter M1 with a range of 0 to 75 amperes. PRESS TO READ switch S3 must be depressed to obtain a reading on M1.

*b. Balance and Regulation Circuits (S1 Set to NORMAL Position).*

- (1) Variable resistor R1 is adjusted to balance the outputs of both full-wave bridge rectifiers by balancing the differences in impedance among the four control windings (terminals 4 and 5 of L1 through L4). Variable resistor R2 is adjusted to balance the outputs of both full-wave bridge rectifiers by balancing the differences in impedance among the four control windings (terminals 6 and 7 of L1 through L4).
- (2) Output voltage regulation is achieved by initially setting VOLTAGE ADJUST R8 for the desired output voltage of the battery charger. This setting will bias the Zener diode CR15 for conduction with the minimum point set by R8 resulting in a minimum flow of current through CR15 to a maximum point set by R8

resulting in a higher value of current flow through CR15. A decrease in the load to the battery charger will result in an increase of output voltage, and the potential across Zener diode CR15 increases. This increase in potential across CR15 will cause a rise in current flow through CR15 and control winding terminals 4 and 5. Simultaneously, an increase in current flows through CR14 and control winding terminals 6 and 7. The current increase through the control winding terminals 4 and 5 and 6 and 7 will increase its impedance and cause a decrease of current flow through the gate winding terminals 1, 2, and 3. The gate windings are a part of the full-wave bridge rectifiers; therefore the decrease of current through the gate windings results in a decrease of voltage output of the full-wave bridge rectifiers to the voltage value initially set on VOLTAGE ADJUST R8. An increase in the load to the battery charger will result in a decrease of output voltage and the potential across Zener diode CR15 decreases. This decrease in potential across CR15 will cause a decrease in current flow through CR15 and control winding terminals 4 and 5. Simultaneously, a decrease in current flows through CR14 and control winding terminals 6 and 7. The decrease in current through control winding terminals 4 and 5 and 6 and 7 will decrease its impedance and cause an increase of current to flow through gate winding terminals 1, 2, and 3. The gate windings are a part of the full-wave bridge rectifiers; therefore the increase of current through the gate windings results in an increase of voltage output of the full-wave bridge rectifiers to the voltage value

initially set on VOLTAGE ADJUST R8.

- (3) Capacitors C2 and C4 in full-wave bridge rectifiers CR1 through CR4, and capacitors C23 and C5 in full-wave bridge rectifiers CR5 through CR8 are used to bypass the high frequency harmonics generated in the magnetic amplifiers (LI through L4). If these harmonics are not bypassed, a slight reduction in the output gain of the magnetic amplifiers may result. Capacitors C22, C23, C24, and C25 are used to suppress the switching transients of CRI through CR8.

*c. Balance, Regulation, and Current Limiting Circuits (S1 Set to CHARGE Position).*

The balance and regulation circuits are the same as discussed in *b* above, except for removal of variable resistor R4 and diode CR14 from the series circuit of control winding terminals 6 and 7. Instead, variable resistor R3 and diode CR9 are used in the series circuit of control winding terminals 6 and 7. With no load applied to the battery charger, diode CR9 is biased to cutoff and no current flows through control winding terminals 6 and 7. With a load applied to the battery charger, diode CR9 is forward biased and current flows through control winding terminals 6 and 7. This circuit permits output currents considerably higher than 50 amperes for 28-volt operation and 25 amperes for 56-volt operation (maximum current output with S1 set to the NORMAL position). With S1 set to the CHARGE position, the maximum output current can be as high as 75 to 80 amperes for 28-volt operation and 37.5 to 40 amperes for 56-volt operation. Under this condition, the high current flowing through control winding terminals 6 and 7 will increase the impedance of gate winding terminals 1, 2, and 3 and result in an output voltage that is too low (approach 0 volt) to be useful. Capacitor C12 bypasses the ac voltage superimposed on the dc voltage and prevents the ac voltage from affecting regulation.

## CHAPTER 2

### TROUBLESHOOTING

---

**Warning:** When servicing the battery charger, be extremely careful of the high voltages.

#### 2-1. General Instructions

Troubleshooting at the direct support, general support, and depot maintenance level includes all the techniques outlined for organizational maintenance and any special or additional techniques required to isolate a defective part. Paragraph 2-4d provides the troubleshooting chart to be used by the repairman.

#### 2-2. Organization of Troubleshooting Procedures

*a. General.* The first step in servicing a defective battery charger is to localize the fault. Localization means tracing the fault to a defective circuit responsible for the abnormal condition. The second step is isolation. Isolation means the locating of the defective part or parts. Some defective parts, such as burned-out resistors and arcing transformers, can oft in be located by sight, smell, or hearing. Most defective parts, however, must be isolated by checking voltages and resistance.

*b. Localization and Isolation.* The first step in tracing trouble is to localize the defective stage by one of the following methods:

- (1) *Visual inspection.* The purpose of visual inspection is to locate faults without testing or measuring circuits. All meter indications or other visual signs should be observed and an attempt made to localize the fault to a particular part.
- (2) *Voltage and resistance measurements.* Use the voltage and resistance values given in paragraph 2-6 and compare them with readings taken.

- (3) *Operational test.* Operational test frequently indicate the general location of trouble. In many instances, the test will help in determining the exact nature of the fault. The daily preventive maintenance checks and services chart (TM 11-6130-236-12) contains a good operational test.
- (4) *Troubleshooting chart.* The troubleshooting chart (para 2-4d) lists symptoms of common troubles and gives (or references) corrective measures. Such a chart obviously cannot include all trouble symptoms that may occur. The repairman should use this chart as a guide in analyzing symptoms that may not be listed.
- (5) *Resistor and color code diagrams.* Color code diagrams for resistors and capacitors (figs. 4-1 and 4-2) provide pertinent resistance, voltage rating, and tolerance information.

#### 2-3. Test Equipment Required

*Note.* Continue using the test equipment listed below until new test equipment, listed in the latest Maintenance Allocation Chart (MAC) of TM 11-6130-236-12, becomes available.

*a. Multimeter TS-352/U and Analyzer ZM-3/U* are required for troubleshooting. Multimeter TS-352/U is used for continuity tests, resistance measurements, and ac or dc voltage measurements. Analyzer ZM-3/U is used to test the capacitors.

*b. The following test equipment and materials* are required to perform the adjustment procedures given in paragraph 2-8:

- (1) Multimeter ME-87/U (2 required), Federal stock No. 6625-223-5248.



- (2) Toggle switch (2 required), Federal stock No. 5930-823-2041.
- (3) Knife switch (2 required), Federal stock No. 5930-224-4928.
- (4) Resistance element, 0.58-ohm, 3,350-watt, Federal stock No. 5905-280-0374.
- (5) Resistance element, 0.86 ohm, 2,150-watt, Federal stock No. 5905-185-8450.
- (6) Resistance element, 1.36 ohm, 2,150-watt, Federal stock No. 5905-186-8451.

**2—4. Localizing Troubles**

*a. General.* Procedures for localizing and isolating troubles within the various circuits of the battery charger are given in the troubleshooting chart (d below). Refer to figure 4-3 for component locations. Refer to the schematic diagram (fig. 4-4) to identify circuit components. Voltage and resistance measurements are given in paragraph 2-6. Depending on the nature of the operational

symptoms, one or more of the localizing procedures will be necessary. When trouble has been localized to a particular circuit, use resistance and voltage measurements to isolate the trouble to a particular part.

*b. Use of Chart.* The troubleshooting chart is designed to supplement the operational checks detailed in TM 11-6130-236-12. If previous operational checks have resulted in reference to a particular item of this chart, go directly to the referenced item. If no operational symptoms are known, start with item 5 of the daily preventive maintenance checks and services chart (TM 11-6130-236-12) and proceed until a trouble symptom appears.

*c. Conditions to Tests.* All checks outlined in the troubleshooting chart are to be conducted with the battery charger connected to a power source. Always remove input power before making any continuity checks with ohmmeter.

*d. Troubleshooting Chart.*

Symptom	Probable trouble	Corrective measures
1. Indicator lamp DS1 does not light and fan motor B1 does not start when power switch and circuit breaker CB1 is set to ON.	DO ac power is applied to battery charger. Defective CB1.	Check for input voltage.  Check CB1; replace if defective.
2. Indicator lamp DS1 lights and fan motor B1 does not operate.	Defective B1.	Replace B1.
3. Fan motor B1 operates and indicator lamp DS1 does not light.	Power transformer T1 secondary winding terminals 9 and 10 open. Defective full-wave bridge rectifier diodes CR10 through CR13.	Check for continuity across terminals 9 and 10 of T1. Replace T1 if necessary. Check CR10 through CR13. Replace defective diode.
4. Indicator lamp DS1 lights but no output voltage is present.	Open in output circuit.  Defective power transformer T1. Defective magnetic amplifiers L1 through L4.	Check for loose connections, broken lead, or faulty component. Replace power transformer T1. Replace defective magnetic amplifier L1 through L4. (Defective magnetic amplifiers must be replaced in matched pairs. L1 and L3 are one matched pair. L2 and L4 are another matched pair.)
5. Erratic output with S1 in NORMAL position. Correct output with S1 in CHARGE position.	Defective resistor R4.  Defective diode CR14.	Replace R4.  Replace CR14.

Symptom	Probable trouble	Corrective measure.
6. Erratic output with S1 in CHARGE position. Correct output with S1 in NORMAL position.	Defective resistor R3.	Replace R3.
	Defective diode CR9.	Replace CR9.
7. Battery charger cannot be balanced during adjustment procedure (para 2-8).	Defective capacitor C12.	Replace C12.
	Defective variable resistor R1.	Check R1 and replace if necessary.
	Defective diode CR15.	Replace CR15.
	Defective capacitor C17.	Replace C17.
	Defective VOLTAGE ADJUST resistor R8.	Check R8 and replace if necessary.
	Defective variable resistor R2.	Check R2 and replace if necessary.
	Defective diode CR14.	Replace CR14.
	Defective variable resistor R4.	Check R4 and replace if necessary.
	Defective winding in one of the magnetic amplifiers (L1, L2, L3, or L4).	Check winding of L1, L2, L3, and L4 (para 2-6) and replace if necessary. (Defective magnetic amplifiers must be replaced in matched pairs. (L1 and L3 are one matched pair. L2 and L4 are the other matched pair).

**2-5. Tests for Open Fuses**

*a. When to Check.*

- (1) When any one of fuses F1 through F4 or F6 through F9 opens continuously with no load connected to the battery charger or when there is no dc output from the battery charger.
- (2) When fuse F5 opens during operation (S1 in NORMAL or CHARGE position).

*b. Conditions for Tests.*

- (1) Disconnect the external power sources connected to receptacle J 1.
- (2) Disconnect any load connected to the DC OUTPUT terminals.
- (3) Remove the covers and panels for access to the components.

*c. Tests.* Make the tests and perform the corrective measures if fuse F1, F2, F3, F4, F6, F7, F8, or F9 is open and the capacitor tested is defective.

Fuse	Capacitor to test	Corrective measure.
F1	C6	Replace C6.
F2	C7	Replace C7.
F3	C8	Replace C8.
F4	C13 and C14	Replace C13 and/or C14.
F6	C9	Replace C9.
F7	C10	Replace C10.
F8	C11	Replace C11.
F9	C15 and C16	Replace C15 or C16.

*d. Additional Tests.* If fuse F5 is open, proceed as follows:

- (1) Test capacitor C17 and replace if defective.
- (2) Test Zener diode CR15 and replace if defective.

**Caution:** Magnetic amplifiers must be replaced in matched pairs. Magnetic amplifiers L1 and L3 are one matched pair; magnetic amplifiers L2 and L4 are the other matched pair.

- (3) Test magnetic amplifiers L1, L2, L3, and L4 (para 2-6). If a magnetic amplifier is defective, replace the defective magnetic amplifier.

**2-6. Additional Troubleshooting Data**

*a. Voltage Output of Power Transformer T1.* The voltage output data of power transformer T1 are provided as an aid to troubleshooting. The voltages of T1 secondary windings are listed below:

Secondary winding terminals	Ac voltage indication (approx)
5-6	42
7-8	42
9-10	30

*b. Dc Resistances of Transformer, Filter Chokes, Relays, and Magnetic Amplifiers.* The dc resistance data ( (3) below) are provided

as an aid to troubleshooting. When using the data, observe the following precautions:

*Caution:* Do not measure resistance when input power is applied to the battery charger and when the power switch and circuit breaker is at ON. Disconnect the power plug and place the power switch and circuit breaker to OFF.

- (1) Before making resistance measurements, determine whether faulty operation is caused by a faulty transformer, filter choke, relay or magnetic amplifier. To do this, follow the troubleshooting procedures as outlined in paragraph 2-4d
- (2) Do not use the resistance measurements as the sole basis to determine that a transformer, filter choke, relay, or magnetic amplifier is defective. Resistances may vary from one transformer, filter choke, relay, or magnetic amplifier to another, because of broad winding tolerances during manufacture. The values given in the chart ( 3) below) are typical average values.
- (3) Dc resistances of transformed, filter chokes, relays, and magnetic amplifiers are as follows:

Transformer, filter chokes, and relays	Terminals	Resistance (ohms)
T1	1-2	Less than 1
	3-4	Less than 1
	5-6	Less than 1
	7-8	Less than 1
	9-10	Less than 1
L5A	3-4	Less than 1
	1-2	Less than 1
K1	X1-X2	110
K2	X1-X2	110
L1, L2, L3, and L4	1-2	Less than 1
	2-3	Less than 1
	4-5	37
	6-7	3

**2-7. General Parts Replacement Techniques**

The battery charger parts can be reached and replaced without special procedures. Refer to figure 4-3 for the location of parts. When

soldering connections to the diodes, solder quickly; use a heat sink (such as long-nosed pliers) between the soldered joint and the diode.

**2-8. Adjustment of Variable Resistors R1, R2, R3, and R4 (fig. 2-1)**

*Caution:* Be sure the battery charger is connected as specified in paragraph 2-3, TM 11-6130-236-12.

Perform the procedures given below after major repair of the battery charger or when the input power source to be used is changed from 50/60 to 400 cps; or from 400 to 50/60 cps.

**a. Resistors R1 and R2, Magnetic Amplifiers Current Balance Adjustment.**

- (1) Remove both of the 28 DC OUTPUT 56 links and connect the negative terminals of each of Multimeters ME-87/U (ammeter) connected as ammeters to each of the terminals marked 28.
- (2) Connect the positive terminals of each of the ammeters to each of the associated unmarked terminals as shown in figure 2-1.
- (3) Remove the shorting links from TB1 and TB2.
- (4) Connect toggle switches to TB1 and TB2 as follows:
  - (a.) The center terminal of one toggle switch to terminal 2 of TB1 and the center terminal of the other toggle switch to terminal 2 of TB2.
  - (b.) Terminal 1 on TB1 to the left terminal of the toggle switch connected to TB1 and terminal 1 on TB2 to the left terminal of the toggle switch connected to TB2.
  - (c.) Terminal 3 on TB1 to the right terminal of the toggle switch connected to TB1 and terminal 3 on TB2 to the right terminal of the toggle switch connected to TB2.
  - (d.) Set both toggle switches to open position.

- (5) Set the NORMAL-CHARGE switch to NORMAL, the 28V-S2-56V switch to 28V, and the VOLTAGE ADJUST control fully counterclockwise.
  - (6) Connect the 1/4-load resistors (1.36-ohm in series with 0.86-ohm, total 2.22-ohms resistance) in series with one knife switch and the full-load resistor (0.58-ohm) in series with the other knife switch to the + OUTPUT - terminals as shown in figure 2-1. Set both knife switches to open position.
  - (7) Set the power switch and circuit breaker to ON. After a 2-minute warmup, apply one-quarter load by closing the knife switch in series with the one-quarter load.
  - (8) Rotate the VOLTAGE ADJUST control for an indication of 28 volts on the OUTPUT VOLTAGE meter.
  - (9) Set the toggle switch connected to TB2 to its left position. Observe and note the indication on each ammeter. Set the same toggle switch to its right position. Observe and note the indication on each ammeter.
  - (10) Set the toggle switch in the position (left or right) that provides the minimum current difference between the two ammeters. (For example, with the toggle switch set to the left, one ammeter indicates 4 amperes and the other ammeter indicates 8 amperes. With the toggle switch set to the right, one ammeter indicates 5 amperes and the other ammeter indicates 7 amperes. For this condition, the toggle switch is set to the right.) Adjust variable resistor R2 until the ammeters indicate the lowest value of imbalance.
  - (11) Remove the one-quarter load by setting the series-connected switch to the open position. Apply full-load by closing the switch in series with the full-load.
  - (12) Readjust R2 as necessary until the ammeters indicate the lowest value of imbalance. The greatest tolerable value of imbalance is 5 amperes of difference between both ammeters with a full load applied. Repair of the battery charger is required if an imbalance greater than 5 amperes exists after adjusting R2.
  - (13) Remove the full load by setting the series connected knife switch to open position.
  - (14) Set the toggle switch connected to TB1 to its left position. Observe and note the indication on each ammeter. Set the same toggle switch to its right position. Observe and note the indication on each ammeter.
  - (15) Set the toggle switch in the position (left or right) that provides the minimum current difference between the two ammeters. Adjust variable resistor R1 until each ammeter indicates 0 current.
  - (16) Set the power switch and circuit breaker to OFF.
  - (17) Disconnect each toggle switch and replace the shorting links across the terminals of TB1 and TB2 that were shorted by the toggle switches for the adjustment of R1 ( (15) above) and R2 (10) above).
- b. Resistor R4 Regulation Adjustment.* After performing the magnetic amplifiers current balance adjustment (a above), adjust variable resistor R4 as follows:
- (1) Set the power switch and circuit breaker to ON. Rotate the VOLTAGE ADJUST control for an indication of 28 volts on the OUTPUT VOLTAGE meter.
  - (2) Apply a full load by closing the knife switch in series with the full load. Adjust variable resistor R4 for an indication between 27.7 volts and 27.9 volts on the OUTPUT VOLTAGE meter.
  - (3) Readjust R2 as necessary for minimum imbalance (a (12) above).
  - (4) Remove the full load by setting the series-connected knife switch to the open position.
  - (5) Set the power switch and circuit breaker to OFF.

- (6) Remove both ammeters from the 28 DC OUTPUT 56 terminals. Replace both of the 28 DC OUTPUT 56 links for 28-volt output power.
- (7) Apply a full load by closing the knife switch in series with the full load. If necessary, readjust R4 for an indication between 27.7 volts and 27.9 volts on the OUTPUT VOLT-AGE meter.
- (8) Set the power switch and circuit breaker to OFF.

*c. Resistor R3 Maximum Current for CHARGE Mode Adjustment.*

- (1) Remove the one-quarter load, full load, both knife switches, and hook-up wire from the + OUTPUT - terminals.
- (2) Rotate variable resistor R3 fully counterclockwise.
- (3) Connect one end of a 10-foot No. 8 AWG wire to the + OUTPUT terminal and the other end of the No. 8 AWG wire to the - OUTPUT terminal. (The 10-foot length of No. 8 AWG wire across the + OUTPUT

- terminals is used to simulate the required short circuit to adjust R3.)
- (4) Set the NORMAL-CHARGE switch to CHARGE.

*Caution:* The procedure, given in (5) below is for CHARGE mode of operation only. Be sure that the NORMAL-CHARGE switch is in the CHARGE position before applying input power to the battery charger.

- (5) Set the power switch and circuit breaker to ON. (The OUTPUT CURRENT meter should indicate between 40 amperes and 50 amperes.)
- (6) Adjust variable resistor R3 for an indication of between 70 amperes and 75 amperes on the OUTPUT CURRENT meter.
- (7) Set the power switch and circuit breaker to OFF.
- (8) Set the NORMAL-CHARGE switch to NORMAL.
- (9) Remove the No. 8 AWG wire from the + OUTPUT - terminals.

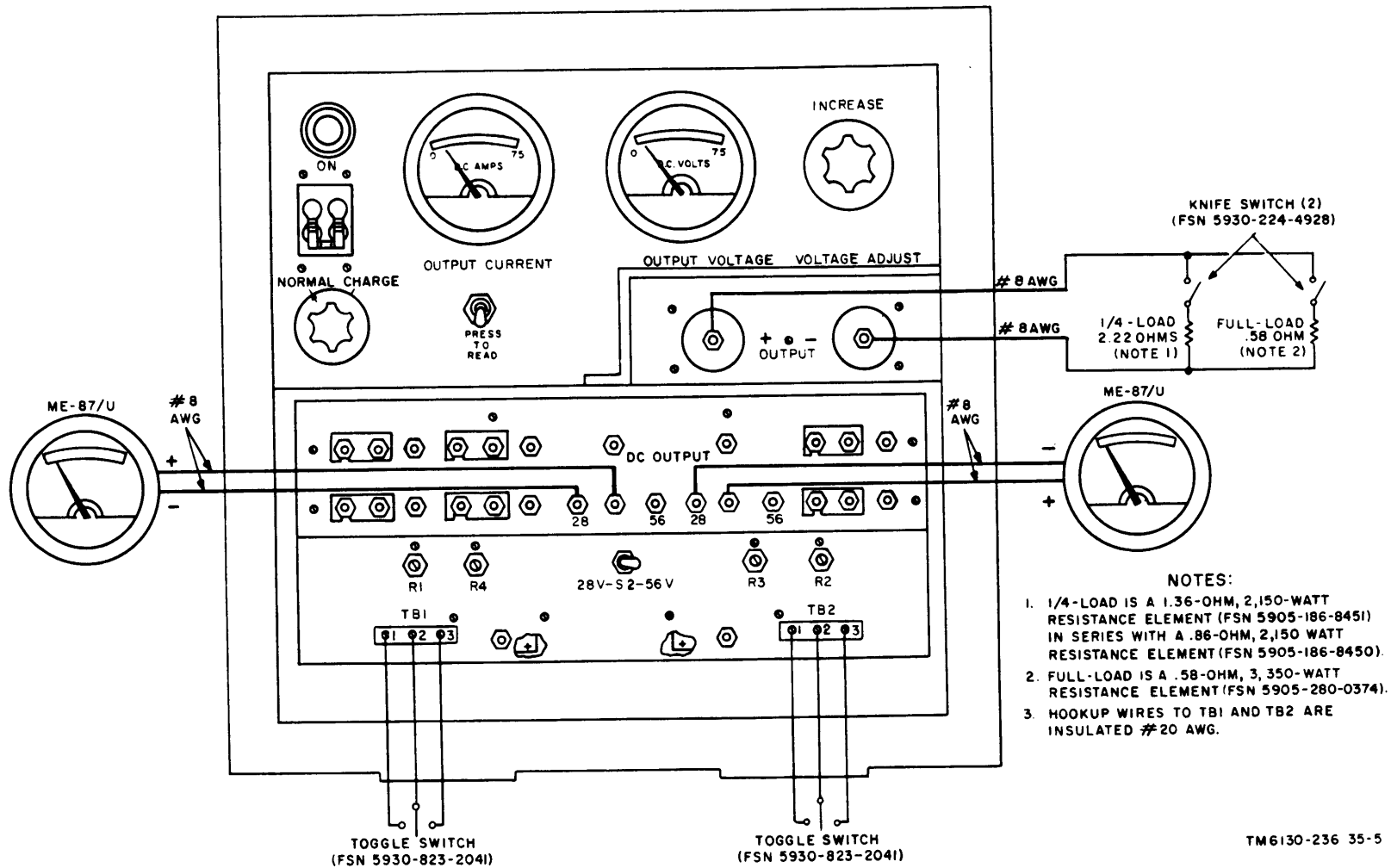

Figure 2-1. Adjustment of variable resistor R1, R2, R3, and R4 connection diagram.

## CHAPTER 3

### GENERAL SUPPORT TESTING PROCEDURES

---

#### 3-1. General

*a.* Testing procedures are prepared for use by Signal Field Maintenance Shops and Signal Service Organizations responsible for general support maintenance of electronic equipment to determine the acceptability of repaired equipment. These procedures set forth specific requirements that repaired equipment *must* meet before it is returned to the using organization. These procedures may also be used as a guide for testing equipment which has been repaired at direct support level if the proper tools and test equipment are available. A summary of the performance standards is given in paragraph 3-8.

*b.* Comply with the instructions preceding each chart before proceeding to the chart. Perform each step in sequence. Do not vary the sequence. For each step, perform all the actions required in

the *Control settings* column; then perform each specific test procedure and verify it against its performance standard.

#### 3-2. Test Equipment, Tools, and Materials

All test equipment, tools, and materials required to perform the testing procedures given in this chapter are listed in *a*, *b*, and *c*, below and are authorized under TA 11-17, (Signal Field Maintenance Shops); and TA 11-100 (11-17), (Allowances of Signal Corps expendable Supplies for Signal Field Maintenance Shops).

*Note.* Continue using the test equipment listed below until new test equipment, listed in the latest Maintenance Allocation Chart (MAC) of TM 11-6130-236-12, becomes available.

*a. Test Equipment.*

Nomenclature	Federal stock No.	Technical manual
Multimeter TS-352/U (2 required)	6625-242-5023	TM 11-5527
Wattmeter TS-430/U	6625-649-5393	None
Transformer, Variable Power TF-171A/U	5950-503-0632	None
Voltmeter, Meter ME30A/U	6625-669-0742	TM 11-6625-320-12
Low Voltage Circuit Tester TV-100	4910-092-9136	None

*b. Tools.* All the tools required are included in Tool Kit, Radio and Radar Repairman TK-87/U.

*c. Materials.*

Nomenclature	Federal stock No.
Wire, electrical, stranded; #10 AWG	6145-160-5110
Resistance Element, 0.58-ohm, 3,350-watt (load for 28-volt tests)	5905-280-0374

Nomenclature	Federal stock No.
Resistance Element, 1.36-ohm, 2,150-watt (part of load for 56-volt tests)	5905-186-8451
Resistance Element, 0.86-ohm, 2,150-watt (part of load for 56- Volt tests)	5905-186-8450
Knife switch (60-ampere)	5930-224-4928



**3-3. Physical Tests and Inspections**

*a. Test Equipment and Materials.* None required.

*b. Test Connections and Conditions.* No connections necessary. Remove panels and covers as necessary for visual and actual access to all components.

*c. Procedures.*

Step No.	Control settings		Test procedure	Performance standard
	Test equipment	Equipment under test		
1	None	Controls may be in any position,	<p><i>a.</i> Inspect case and chassis for damage, missing parts, and condition of paint.  <i>Note.</i> Touchup painting is recommended in lieu of refinishing whenever practical; screw-heads, binding posts, receptacles, and other plated parts will not be painted or polished with abrasives.</p> <p><i>b.</i> Inspect all controls and mechanical assemblies for loose or missing screws, bolts, and nuts.</p> <p><i>c.</i> Inspect all connectors, receptacles, meters, and fuseholders for looseness, damage, or missing parts.</p>	<p><i>a.</i> No damage evident or parts missing. External surfaces intended to be painted do not show bare metal. Panel lettering will be legible.</p> <p><i>b.</i> Screws, bolts, and nuts are tight. None missing.</p> <p><i>c.</i> No loose parts or damage. No missing parts.</p>
2	None	Controls may be in any position.	<p><i>a.</i> Rotate all panel controls through their limits of travel.</p> <p><i>b.</i> Operate all switches.</p>	<p><i>a.</i> Controls rotate freely without binding or excessive looseness.</p> <p><i>b.</i> Switches operate properly.</p>
3	None	Controls may be in any position.	Manually turn fan blades of motor B1.	Fan blades turn freely without binding.

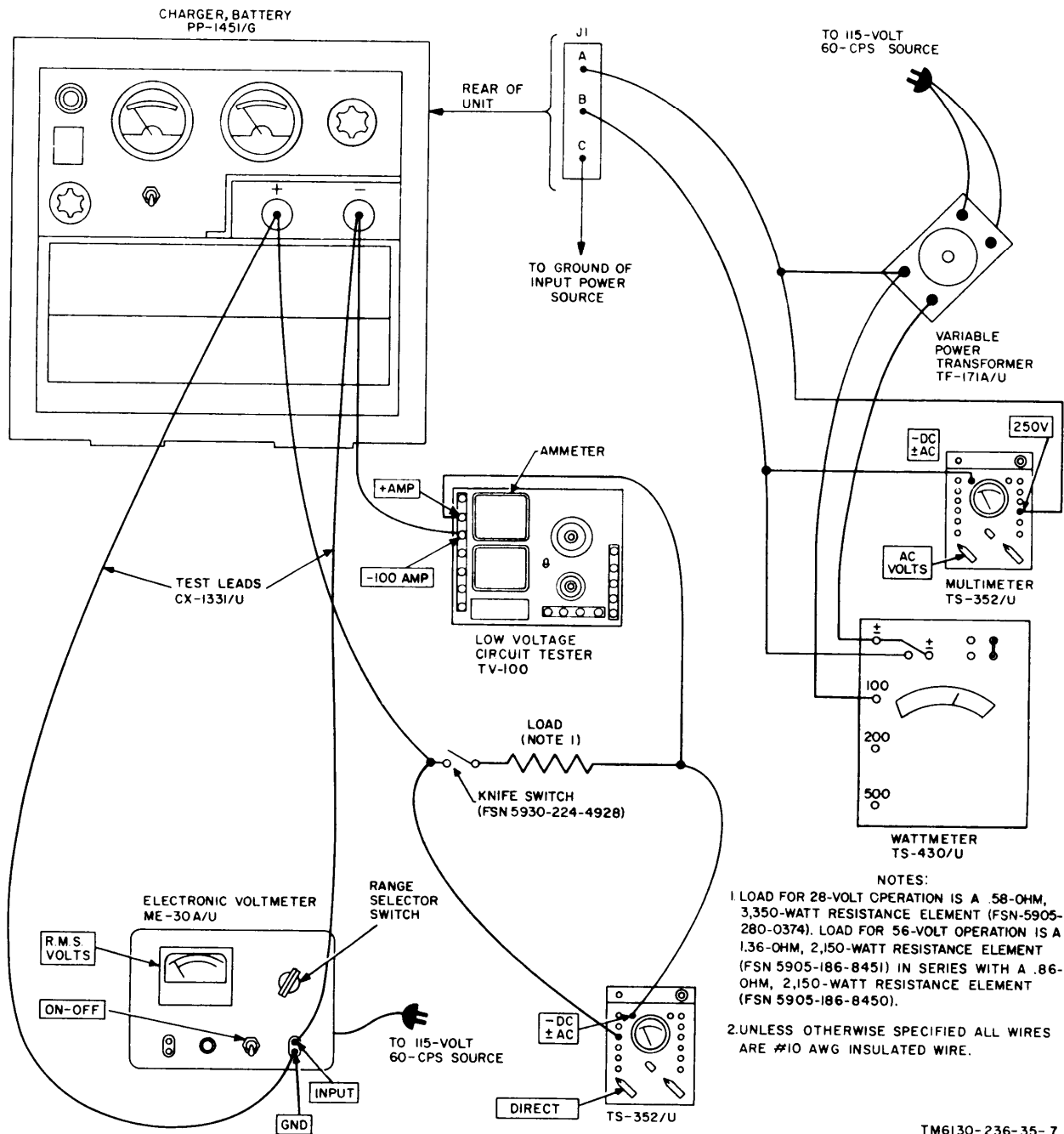

Figure 3-1. Twenty-eight Volt output, regulation, ripple, and efficiency test connection diagram.

**115 Volt Output, Regulation, Ripple, and Efficiency Test**

**Equipment and Materials.**

meter ME-30A/U.

TS-352/U (2 required).

SN 6625-849-0585) with Meter Shunt (FSN 6625-884-8964).

Variable Power TF-171A/U.

TS-430/U.

(FSN 5930-224-4928).

Resistor element 0.58-ohm, 3,350-watt (FSN 5905-280-0374).

(as fabricated).

**Procedure and Conditions.** Connect the equipment as shown in figure 3-1. Be sure that the knife switch in figure 3-1 is in the open position. This test is written for 115-volts, 60-CPS operation.

Control settings	Equipment under test	Test procedure	Performance standard
7.	<p>Power switch and circuit breaker: OFF</p> <p>VOLTAGE ADJUST control: fully counterclockwise.</p> <p>NORMAL-CHARGE switch: NORMAL</p> <p>28V-S2-56V switch: 28V</p>	<p>a. Connect PP-1451/G for 115-volts, 60-cps, input power.</p> <p>b. Connect the equipment to a 115-volt, 60-cps source.</p> <p>c. Adjust the control on TF-171 A/U for 115-volt ac output.</p> <p>d. With the knife switch in series with the load in open position, set the power switch and circuit breaker to ON. Rotate the VOLTAGE ADJUST control throughout its range while observing the indication on PP-1451/G OUTPUT VOLTAGE meter.</p> <p>e. Rotate the VOLTAGE ADJUST control until an indication of 28 volts is observed on the TS-352/U connected to output voltage.</p> <p>f. Observe the indication on OUTPUT VOLTAGE meter on the PP-1451/G.</p> <p>g. Apply the load (0.58-ohm resistance) by closing the switch in series with the load. While observing the indication on the TV-100 (ammeter) in series with the load, rotate the VOLTAGE ADJUST control until the ammeter in series with the load indicates 50 amperes. Observe the indication on the OUTPUT CURRENT meter on the PP-1451/G.</p> <p>h. Observe and note the indication on the TS-352/U connected to the output voltage and the OUTPUT VOLTAGE meter on the PP-1451/G.</p> <p>i. Observe the indication on TS-430/U.</p> <p>j. Observe the indication on ME-30A/U.</p> <p>k. Remove the load by setting the switch in series with the load to open position. Observe the indication on OUTPUT VOLTAGE meter on the PP-1451/G.</p> <p>l. Set NORMAL-CHARGE switch to CHARGE. Apply the load by closing the switch in series with the load. Rotate the VOLTAGE ADJUST control until the ammeter in series with the load indicates 40 amperes.</p> <p>m. Remove the load by setting the switch in series with the load to open position. Set NORMAL-CHARGE switch to NORMAL. Adjust TF-171 A/U until TS-352/U connected to input voltage indicates 105 volts ac. Apply the load by closing the switch in series with the load. Rotate the VOLTAGE ADJUST control until ammeter in series with the load indicates 50 amperes.</p> <p>n. Remove the load by setting the switch in series with the load to open position. Adjust TF-171A/U until TS-352/U connected to input voltage indicates 125 volts ac. Apply the load by closing the switch in series with the load. Rotate the VOLTAGE ADJUST control until ammeter in series with the load indicates 50 amperes.</p> <p>o. Remove the load by setting the switch in series with the load to open position. Set the power switch and circuit breaker to OFF.</p>	<p>a. None.</p> <p>b. None</p> <p>c. None</p> <p>d. Minimum reading is 26 volts or less. Maximum reading is 30 volts or greater.</p> <p>e. Reading is 28 volts.</p> <p>f. Reading is 28 volts ± 1.</p> <p>g. Reading on ammeter is 50 amperes. Reading on OUTPUT CURRENT meter is 50 ± 2 amperes.</p> <p>h. Readings do not differ greater than 2 volts between both meters.</p> <p>i. Reading must not exceed 2,600 watts.</p> <p>j. Reading must not exceed 0.450 volt.</p> <p>k. The difference of this reading to the reading obtained in h above is less than 1.5 percent.</p> <p>l. Reading is 40 amperes.</p> <p>m. Reading is 50 amperes.</p> <p>n. Reading is 50 amperes.</p> <p>o. None</p>
8.	<p>Same as for step 1 above except that 28V-S2-56V switch is set to 56V.</p>	<p>a. Same as step 1a above.</p> <p>b. Same as step 1b above.</p> <p>c. Same as step 1c above.</p> <p>d. With the knife switch in series with the load in open position, set the power switch and circuit breaker to ON. Rotate VOLTAGE ADJUST control throughout its range while observing the indication on OUTPUT VOLTAGE meter on the PP-1451/G.</p> <p>e. Apply the load (2.22 ohms resistance) by closing the switch in series with the load. Observe the indication on the ammeter in series with the load. Rotate the VOLTAGE ADJUST control until the ammeter in series with the load indicates 25 amperes.</p> <p>f. Remove the load. Set the power switch and circuit breaker to OFF. Set 28V-S2-56V switch to 28V. Turn power off to all test equipment.</p>	<p>a. None</p> <p>b. None</p> <p>c. None</p> <p>d. Minimum reading is 52 volts or less. Maximum reading is 60 volts or greater.</p> <p>e. Reading is 25 amperes.</p> <p>f. None.</p>

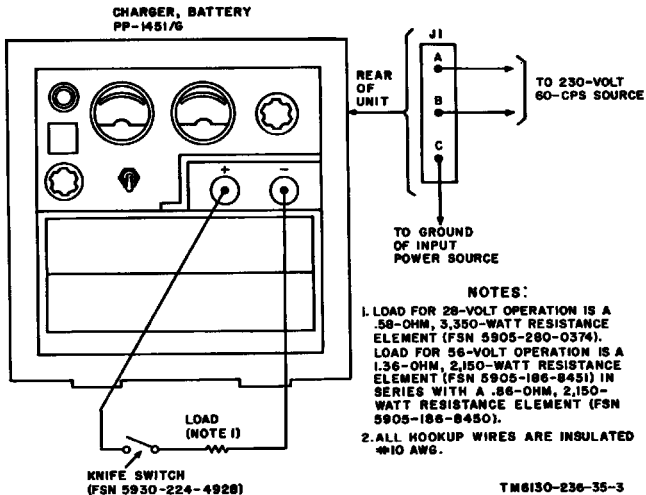

Figure 3-2. Two hundred and thirty volts, 60-cps input power test connection diagram.

**3-5. Two Hundred and Thirty Volts, 60-cps Input Power Test**

*a. Test Equipment and Materials.*

- Resistance Element, 0.58-ohm, 3,350-watt (FSN 5905-280-0374).
- Resistance Element, 1.36-ohm, 2,150-watt (FSN 5905-186-8451).
- Resistance Element, 0.86-ohm, 2,150-watt (FSN-5905-186-8450).
- Knife switch (FSN 5930-224-4928).
- Power cable (as fabricated).

*b. Test Connections and Conditions.* Connect the equipment as shown in figure 3-2. Be sure that the knife switch in series with the load is in open position. This test is written for 230-volts, 60-cps operation.

*c. Procedure.*

Step No.	Control settings		Test procedure	Performance standard
	Test equipment	Equipment under test		
1	Load: 0.58-ohm, 3,350-watt resistor.	Power switch and circuit breaker: OFF. VOLTAGE ADJUST control: Fully counterclockwise. NORMAL-CHARGE switch: NORMAL. 28V-S2-56V switch: 28V	<ul style="list-style-type: none"> <li>a. Connect PP-1451/G for 230-volt, 60-cps input power.</li> <li>b. Connect PP-1451/G to a 230-volt, 60-cps source.</li> <li>c. With the knife switch in series with the load in open position, set the power switch and circuit breaker to ON. Rotate the VOLTAGE ADJUST control throughout its range while observing the indication on OUTPUT VOLTAGE meter.</li> <li>d. Apply the load (0.58-ohm resistance): While observing the indication on the OUTPUT CURRENT meter, rotate the VOLTAGE ADJUST control until the OUTPUT CURRENT meter indicates 50 amperes.</li> <li>e. Remove the load by setting the switch in series with the load to open position. Set the power switch and circuit breaker to OFF.</li> </ul>	<ul style="list-style-type: none"> <li>a. None.</li> <li>b. None.</li> <li>c. Minimum reading is 26 volts or less. Maximum reading is 30 volts or greater.</li> <li>d. Reading is 50 amperes.</li> <li>e. None</li> </ul>
2	Load: 1 each, 0.86-ohm, 2,150-watt and 1 each, 1.36-ohm, 2,150-watt resistors connected in series.	Same as for step 1 above except that 28V-S2-56V switch is set to 56V.	<ul style="list-style-type: none"> <li>a. Same as step 1c above.</li> <li>b. Same as step 1b above.</li> <li>c. Same as step 1c above.</li> <li>d. Apply the load (2.22 ohm resistance). While observing the indication on the OUTPUT CURRENT meter, rotate the VOLTAGE ADJUST control until the OUTPUT meter indicates</li> </ul>	<ul style="list-style-type: none"> <li>a. None</li> <li>b. None</li> <li>c. Minimum reading is 52 volts or less. Maximum reading is 60 volts or greater.</li> <li>d. Reading is 25 amperes.</li> </ul>

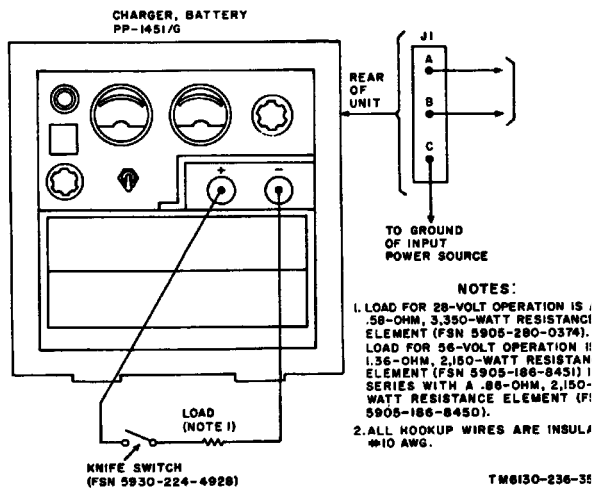

Figure 3-2. One hundred and fifteen volts, 100-ops input power test connec diagram.

**3-6. One Hundred and Fifteen Volts, 400-cps Input Power Test**

*a. Test Equipment and Materials.*

- Resistance Element, 0.58-ohm, 3,350-watt (FSN 5905-280-0374).
- Resistance Element, 1.36-ohm, 2,150-watt (FSN 5905-186-8451).
- Resistance Element, 0.86-ohm, 2,150-watt (FSN 5905-186-8450).
- Knife switch (FSN 5930-224-4928).
- Power cable (as fabricated).

*b. Test Connections and Conditions.* Connect the equipment as shown in figure 3-3. Be sure that the knife switch in series with the load is in open position. This test is written for 115-volts, 400-cps operation. (The adjustment procedures given in paragraph 2-8 should be performed before proceeding with this test).

*c. Procedure.*

Step No.	Control settings		Test procedure	Performance standard
	Test equipment	Equipment under test		
1		Power switch and circuit breaker: OFF. VOLTAGE ADJUST control: Fully counterclockwise. NORMAL-CHARGE switch:	a. Connect PP-1451/G for 115-volt, 400-cps, input power. b. Connect PP1451/G to a 115-volt, 400-cps source. c. With the knife switch in series with the load in open position, set the power switch and circuit breaker to ON. Rotate the VOLTAGE ADJUST control throughout its range while observing the indication on OUTPUT VOLTAGE meter. d. Apply the load (0.58-ohm resistance). While observing the indication on the OUTPUT CURRENT meter, rotate the VOLTAGE ADJUST control until the OUTPUT CURRENT meter indicates 50 amperes. e. Remove the load by setting the switch in series with the load to open position. Set the power switch and circuit breaker to OFF.	a. None. b. None c. Minimum reading is 26 volts or less. Maximum reading is 30 volts or greater. d. Reading is 50 amperes. e. None.
2	Load: 1 each, 0.86 ohm, 2,150-watt and 1 each, 1.36-ohm, 2,150-watt resistors connected in series (Total load resistance is 2.22 ohms.)	Same as for step 1 above except that 28V-S2-56V switch is set to 56V.	a. Same as step 1a. above. b. Same as step 1b. above. c. Same as step 1c. above. d. Apply the load (2.22 ohms resistance). While observing the indication on the OUTPUT CURRENT meter, rotate the VOLTAGE ADJUST control until the OUTPUT CURRENT meter indicates 25 amperes. e. Remove the load by setting the switch in series with the load to open position. Set the power switch and circuit breaker to OFF.	a. None. b. None. c. Minimum reading is 52 volts or less. Maximum reading is 60 volts or greater. d. Reading is 25 amperes. e. None.

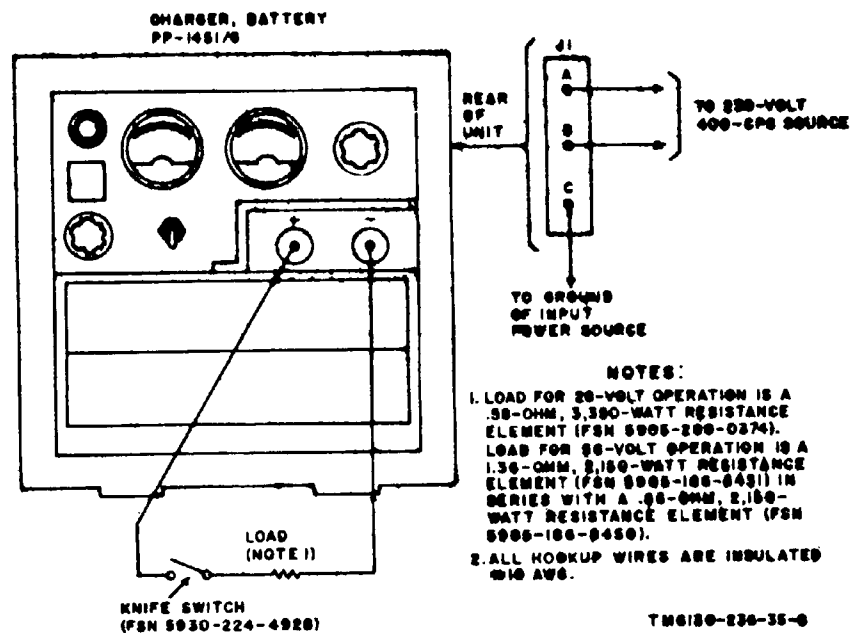

Figure 3-4. Two hundred and thirty volts, 400-cps input power test connection diagram.



**3-7. Two Hundred and Thirty Volts, 400-cps Input Power Test**

*a. Test Equipment and Materials.*

Resistance Element, 0.58-ohm, 3,350-watt (FSN 5905-280-0374)

Resistance Element, 1.36-ohm, 2,150-watt (FSN 5905-186-8451)

Resistance Element, 0.86-ohm, 2,150-watt (FSN 5905-186-8450)

Knife switch (FSN 5930-224-4928)

Power cable (as fabricated)

*b. Test Connections and Conditions.* Connect the equipment as shown in figure 3-4. Be sure that the knife switch in series with the load is in open position. This test is written for 230-volt, 400-cps operation.

*c. Procedure.*

Step No.	Control settings		Test procedure	Performance standard
	Test equipment	Equipment under test		
1	Load: 1 each, 0.58-ohm, 3,350-watt resistor.	Power switch and circuit breaker: OFF VOLTAGE ADJUST control: Fully counterclockwise. NORMAL-CHARGE switch: NORMAL 28V-S2-58V switch: 28V	<p>a. Connect PP-1451/G for 230-volt, 400-cps, input power.</p> <p>b. Connect PP-1451/G to 230-volt, 400-cps source.</p> <p>c. With the knife switch in series with the load in open position, set the power switch and circuit breaker to ON. Rotate the VOLTAGE ADJUST control throughout its range while observing the indication on OUTPUT VOLTAGE meter.</p> <p>d. Apply the load (0.58-ohm resistance). While observing the indication on the OUTPUT CURRENT meter, rotate the VOLTAGE ADJUST control until the OUTPUT CURRENT meter indicates 50 amperes.</p> <p>e. Remove the load by setting the switch in series with the load to open position. Set the power switch and circuit breaker to OFF.</p>	<p>a. None.</p> <p>b. None.</p> <p>c. Minimum reading is 26 volts or less. Maximum reading is 30 volts or greater.</p> <p>d. Reading is 50 amperes.</p> <p>e. None.</p>
2	Load: 1 each, 0.86-ohm, 2,150-watt and 1 each, 1.36-ohm, 2,150-watt resistors connected in series. (Total load resistance is 2.22 ohms.)	Same as for step 1 above except that 28V-S2-56V switch is set to 56V.	<p>a. Same as step 1a above.</p> <p>b. Same as step 1b above.</p> <p>c. Same as step 1c above.</p> <p>d. Apply the load (2.22-ohm resistance). While observing the indication on the OUTPUT CURRENT meter, rotate the VOLTAGE ADJUST control until the OUTPUT CURRENT meter indicates 25 amperes.</p> <p>e. Remove the load by setting the switch in series with the load to open position. Set the power switch and circuit breaker to OFF.</p>	<p>a. None.</p> <p>b. None.</p> <p>c. Minimum reading is 52 volts or less. Maximum reading is 60 volts or greater.</p> <p>d. Reading is 25 amperes.</p> <p>e. None.</p>

**3-8. Test Data Summary**

*a. Input.*

- (1) Voltage.....115 volts or 230 volta.
- (2) Frequency.....50/60 cps or 400 cps.
- (3) Phase.....Single.
- (4) Power (full load)...2,600 watts maximum.

*b. Output.*

- (1) Voltage.....28-volt operation (from  
26 to 30 volts dc).  
56-volt operation (from  
52 to 60 volts dc).
- (2) Current (max-  
imum). 50 amperes for 28-volt  
operation.  
25 amperes for 56-volt  
operation.
- (3) Ripple voltage 0.420 volt for 28-volt  
(maximum). operation.  
0.840 volt for 56-volt  
operation.

- (4) Voltage regula- 1.5 percent maximum  
tion. (NORMAL-CHARGE  
switch set to NORMAL  
position only).

*c. Formulas Used.*

$$\% \text{ Regulation} = \frac{E_{NL} - E_L}{E_L} \times 100.$$

$$\% \text{ Riggle} = \frac{E_{RMS}}{E_{DC}} \times 100.$$

Where,

$E_{NL}$  is voltage measured under no-load conditions.

$E_L$  is voltage measured under full-load conditions.

$E_{RMS}$  is the measured ripple voltage.

$E_{DC}$  is the measured dc output voltage.

## CHAPTER 4

### DEPOT OVERHAUL STANDARDS

#### 4-1. Applicability of Depot Overhaul Standards

The tests outlined in this chapter are designed to measure the performance capability of a repaired equipment. Equipment that is to be returned to stock should meet the standards given in these tests.

#### 4-2. Applicable References

*a. Repair Standards.* Applicable procedures of the depots performing these tests and the general standards for repaired electronic equipment

give in TB SIG 355-1, TB SIG 355-2, and TB SIG 355-3 form a part of the test requirements.

*b. Technical Publication.* The technical publication applicable to the equipment to be tested is TM 11-6130-236-12.

*c. Modification Work Orders.* Perform all modification work orders applicable to this equipment before making the tests specified. DA Pam 310-4 lists all available MWO's.

#### 4-3. Test Facilities Required

The following items are required for depot testing:

#### *a. Test Equipment.*

*Note.* Continuing using the test equipment listed below until new test equipment, listed in the latest Maintenance Allocation Chart (MAC) of TM 11-6130-236-12, becomes available.

Item	Federal stock No.	Technical manual
Multimeter TS-352/U (2 required)	6625-242-5023	TM 11-5527
Wattmeter TS-430/U	6625-649-5393	None
Transformer, Variable Power TF-171A/U	5950-503-0632	None
Voltmeter, Meter ME-30A/U	6625-669-0742	TM 11-6625-320-12
Low Voltage Circuit Tester TV-100	4910-092-9136	None

#### *b. Materials*

Nomenclature	Federal stock No.
Wire, electrical stranded; #10 AWG	6145-160-5110
Resistance Element, 0.53-ohm, 3,350-watt (load for 23-volt tests)	5905-280-0374
Resistance Element, 1.36-ohm, 2,150-watt (part of load for 56-volt tests)	5905-186-3451
Resistance Element, 0.36	5905-136-3450

Nomenclature	Federal duck No.
ohm, 2,150-watt (part of load for 56 vote tests)	
Knife switch (60 ampere)	5930-224-4928

#### 4-4 Tests

The depot overhaul standards test procedures are the same as those for general support (para 3-4 through 3-7). Equipment that meets the performance standards stated in these tests will furnish satisfactory operation equivalent to that of new equipment.

**COLOR CODE MARKING FOR MILITARY STANDARD RESISTORS**

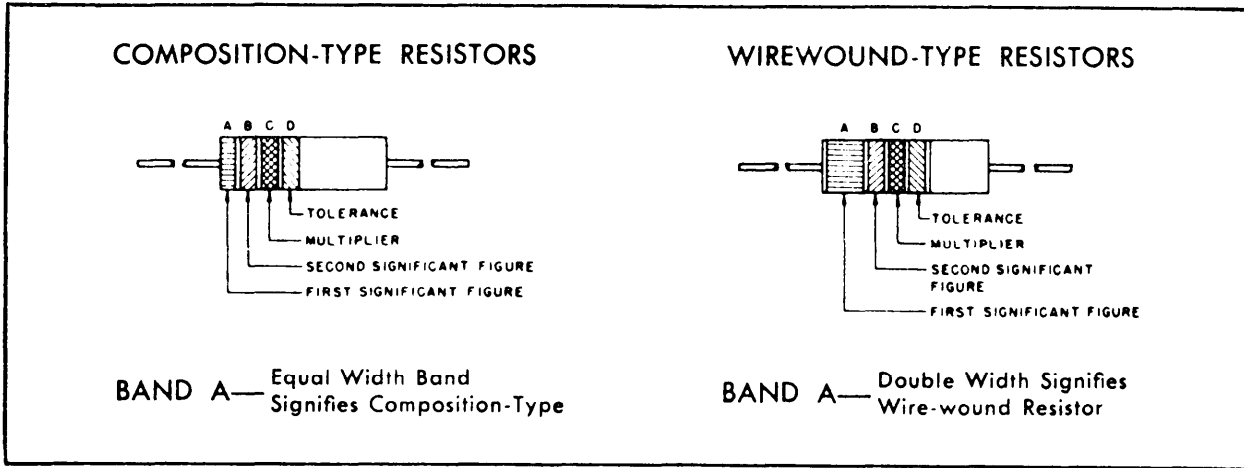

**COLOR CODE TABLE**

BAND A		BAND B		BAND C		BAND D*	
COLOR	FIRST SIGNIFICANT FIGURE	COLOR	SECOND SIGNIFICANT FIGURE	COLOR	MULTIPLIER	COLOR	RESISTANCE TOLERANCE (PERCENT)
BLACK	0	BLACK	0	BLACK	1		
BROWN	1	BROWN	1	BROWN	10		
RED	2	RED	2	RED	100		
ORANGE	3	ORANGE	3	ORANGE	1,000		
YELLOW	4	YELLOW	4	YELLOW	10,000	SILVER	± 10
GREEN	5	GREEN	5	GREEN	100,000	GOLD	± 5
BLUE	6	BLUE	6	BLUE	1,000,000		
PURPLE (VIOLET)	7	PURPLE (VIOLET)	7				
GRAY	8	GRAY	8	SILVER	0.01		
WHITE	9	WHITE	9	GOLD	0.1		

**EXAMPLES OF COLOR CODING**

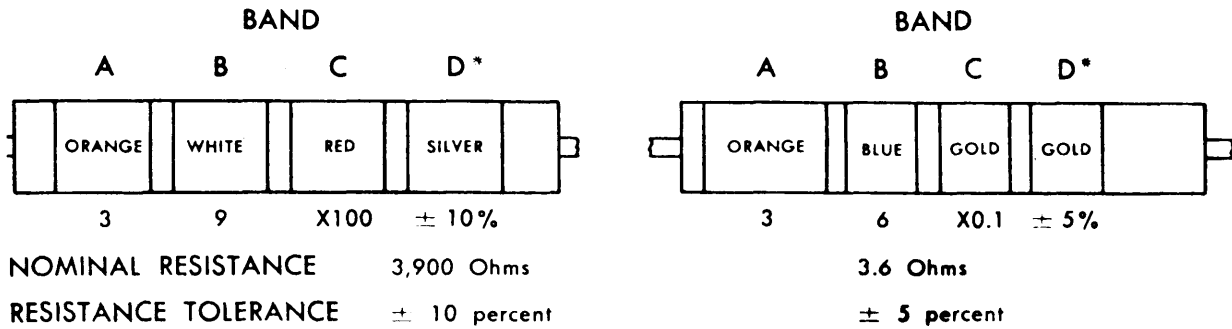

\*If B and D is omitted, the resistor tolerance is .±. 20%, and the resistor is not Mil-Std.

Figure 4-1. Color code marking for MIL STD resistors.

STD-R2

COLOR CODE MARKING FOR MILITARY STANDARD CAPACITORS

GROUP I Capacitors, Fixed, Various-Dielectrics, Styles CM, CN, CY, and CB

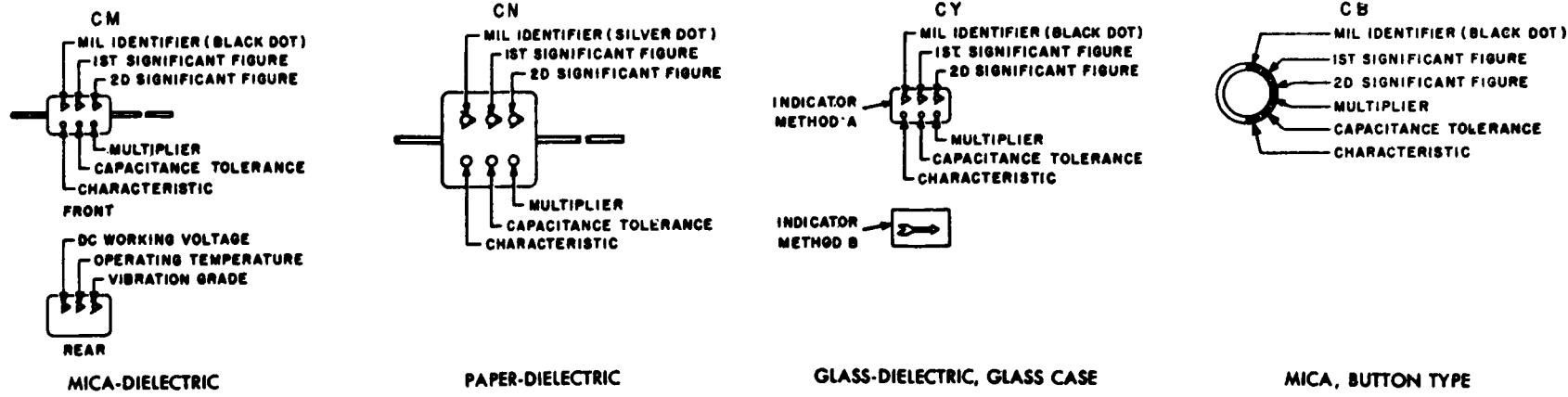

GROUP II Capacitors, Fixed Ceramic-Dielectric (General Purpose) Style CK

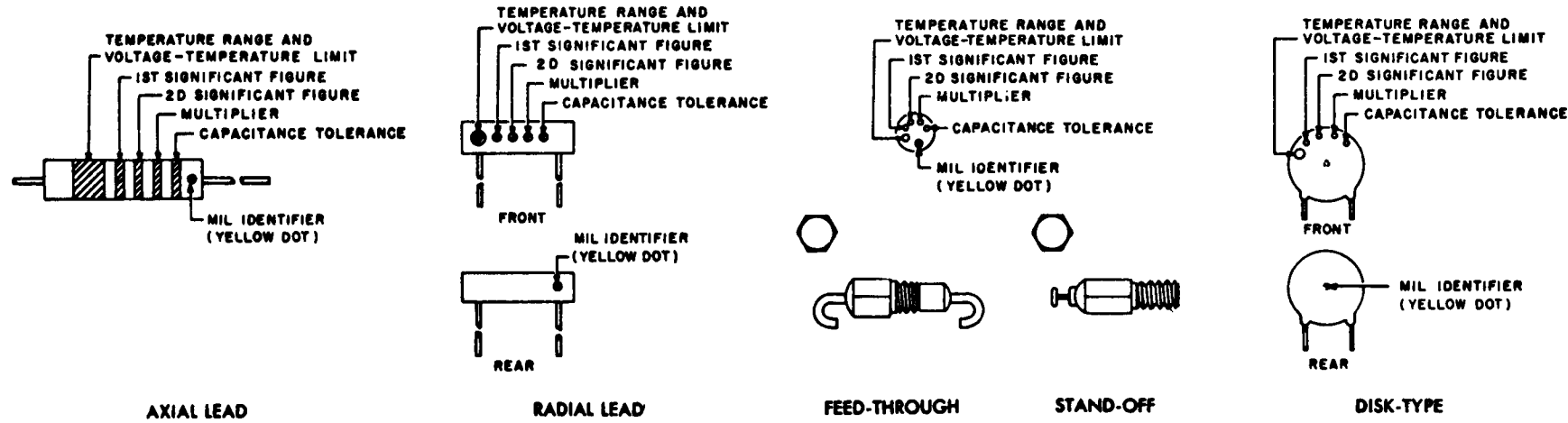

GROUP III Capacitors, Fixed, Ceramic-Dielectric (Temperature Compensating) Style CC

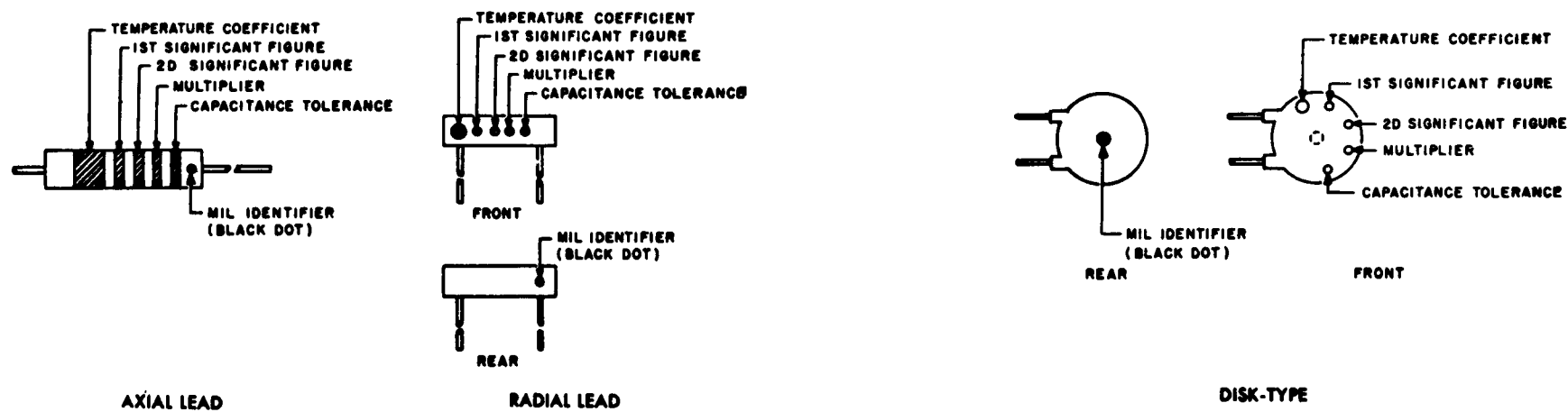

COLOR CODE TABLES

TABLE I - For use with Group I, Styles CM, CN, CY and CB

COLOR	MIL ID	1st SIG FIG	2nd SIG FIG	MULTIPLIER <sup>1</sup>	CAPACITANCE TOLERANCE				CHARACTERISTIC <sup>2</sup>				DC WORKING VOLTAGE	OPERATING TEMP. RANGE	VIBRATION GRADE
					CM	CN	CY	CB	CM	CN	CY	CB	CM	CM	CM
BLACK	CM, CY CB	0	0	1			± 20%	± 20%		A				-55° to +70°C	10-55 cps
BROWN		1	1	10					B	E		B			
RED		2	2	100	± 2%		± 2%	± 2%	C		C			-55° to +85°C	
ORANGE		3	3	1,000		± 30%			D			D	300		
YELLOW		4	4	10,000					E					-55° to +125°C	10-2,000 cps
GREEN		5	5		± 5%				F				500		
BLUE		6	6											-55° to +150°C	
PURPLE (VIOLET)		7	7												
GREY		8	8												
WHITE		9	9												
GOLD				0.1			± 5%	± 5%							
SILVER	CN				± 10%	± 10%	± 10%	± 10%							

TABLE II - For use with Group II, General Purpose, Style CK

COLOR	TEMP. RANGE AND VOLTAGE - TEMP. LIMITS <sup>3</sup>	1st SIG FIG	2nd SIG FIG	MULTIPLIER <sup>1</sup>	CAPACITANCE TOLERANCE	MIL ID
BLACK		0	0	1	± 20%	
BROWN	AW	1	1	10	± 10%	
RED	AX	2	2	100		
ORANGE	BX	3	3	1,000		
YELLOW	AV	4	4	10,000		CK
GREEN	CZ	5	5			
BLUE	BV	6	6			
PURPLE (VIOLET)		7	7			
GREY		8	8			
WHITE		9	9			
GOLD						
SILVER						

TABLE III - For use with Group III, Temperature Compensating, Style CC

COLOR	TEMPERATURE COEFFICIENT <sup>4</sup>	1st SIG FIG	2nd SIG FIG	MULTIPLIER <sup>1</sup>	CAPACITANCE TOLERANCE		MIL ID
					Capacitances over 10uuf	Capacitances 10uuf or less	
BLACK	0	0	0	1		± 2.0uuf	CC
BROWN	-30	1	1	10	± 1%		
RED	-80	2	2	100	± 2%	± 0.25uuf	
ORANGE	-150	3	3	1,000			
YELLOW	-220	4	4				
GREEN	-330	5	5		± 5%	± 0.5uuf	
BLUE	-470	6	6				
PURPLE (VIOLET)	-750	7	7				
GREY		8	8	0.01			
WHITE		9	9	0.1	± 10%		
GOLD	+100					± 1.0uuf	
SILVER							

1. The multiplier is the number by which the two significant (SIG) figures are multiplied to obtain the capacitance in uuf.
2. Letters indicate the Characteristics designated in applicable specifications: MIL-C-5, MIL-C-91, MIL-C-11272, and MIL-C-10950 respectively.
3. Letters indicate the temperature range and voltage-temperature limits designated in MIL-C-11015.
4. Temperature coefficient in parts per million per degree centigrade.

Figure 4-2. Color code marking for MIL STD capacitors.

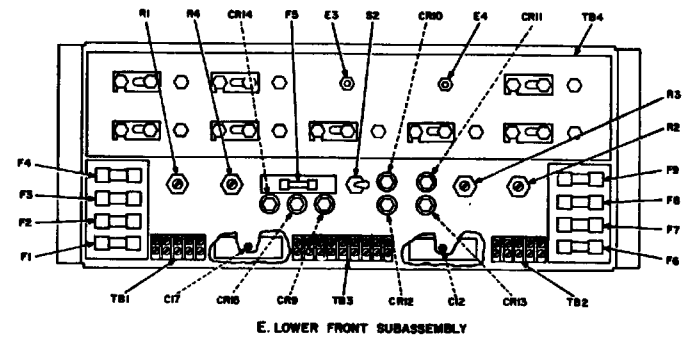
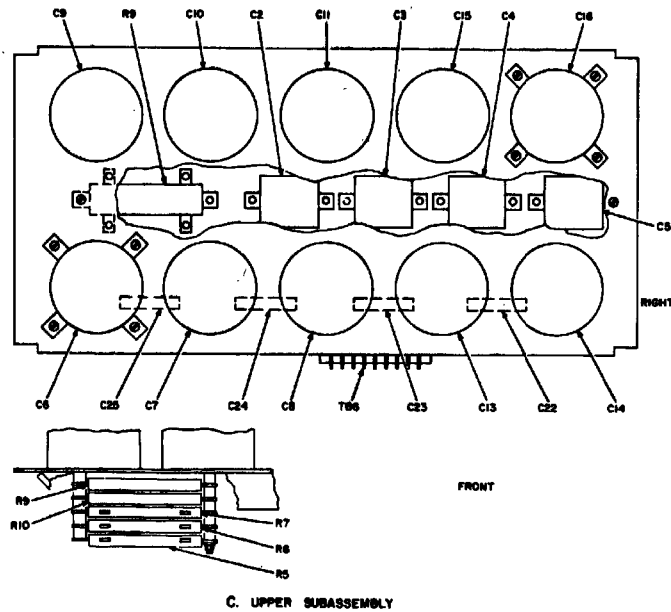
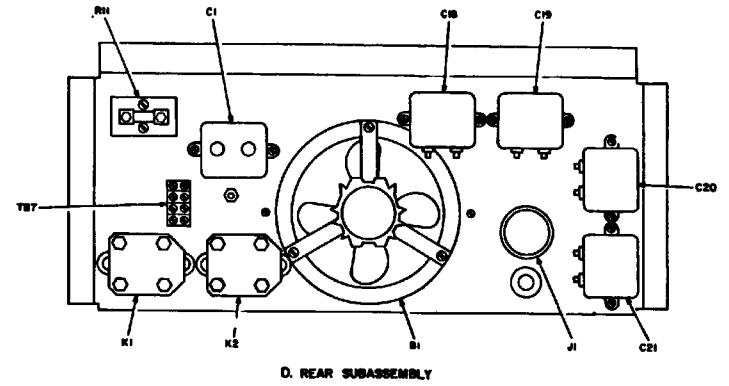
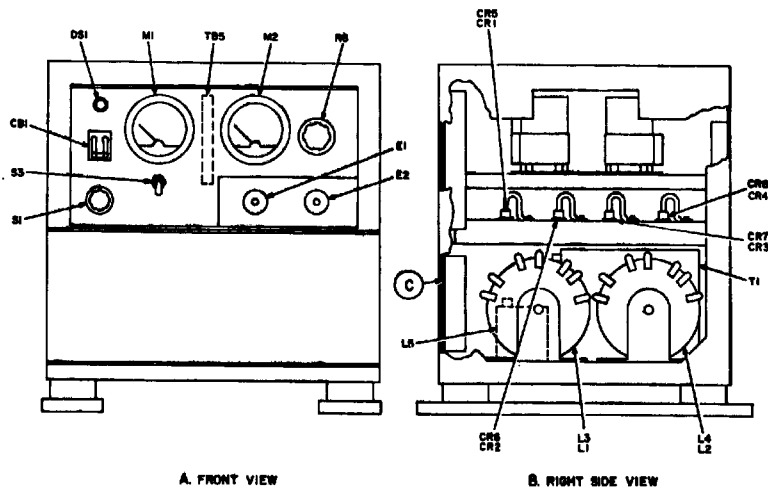
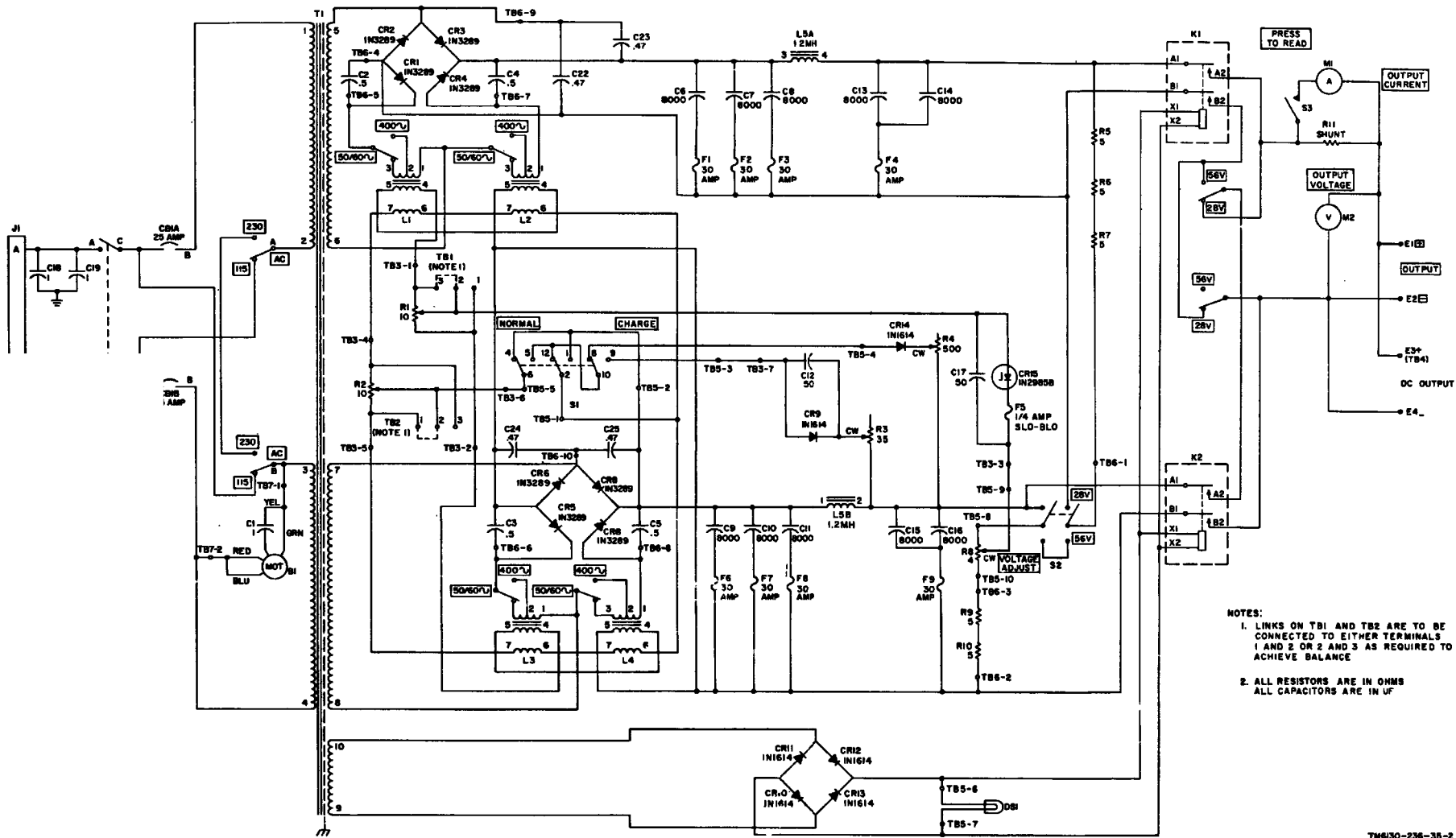

Figure 4-3. Charger, Battery PP-1451/G, parts location.



- NOTES:
- LINKS ON TBS1 AND TBS2 ARE TO BE CONNECTED TO EITHER TERMINALS 1 AND 2 OR 2 AND 3 AS REQUIRED TO ACHIEVE BALANCE
  - ALL RESISTORS ARE IN OHMS  
ALL CAPACITORS ARE IN UF

TW6130-236-35-2

Figure 4-4. Charger, Battery PP-1151/G, schematic diagram.

## APPENDIX

### REFERENCES

---

DA Pam 310-4	Index of Technical Manuals, Technical Bulletins, Supply Manuals (types 7, 8, and 9), Supply Bulletins, Lubrication Orders, and Modification Work Orders.
TA 11-17	Signal Field Maintenance Shops.
TA 11-100 (11-17)	Allowances of Signal Corps Expendable Supplies for Signal Field Maintenance Shops.
TM 11-487H-1/1	Electronic Test Equipment.
TM 11-5043-12	Operator's and Organizational Maintenance Manual: Analyzers ZM-3/U and ZM-3A/U.
TM 11-5527	Multimeters TS-352/U, TS-352A/U, and TS-352B/U.
TM 11-6130-236-12	organizational Maintenance Manual: Charger, Battery PP-1451/G.
TM 11-6130-236-25P	organizational, DS, GS, and Depot Maintenance Repair Parts and Special Tool Lists: Charger, Battery PP-1451/G.
TM 11-6625-320-12	organizational Maintenance Manual: Voltmeter, Meter ME-30A/U and Voltmeters, Electronic ME-30B/U, ME-30C/U, and ME-30E/U.



By Order of the Secretary of the Army:

HAROLD K. JOHNSON,  
General, United States Army.  
Chief of Staff.

Official:

J. C. LAMBERT,  
Major General, United States Army,  
The Adjutant General.

Distribution:

*Active Army:*

USASA (2)	320th USASA Bn (2)	Ft Monmouth (70)
CNGB (1)	177th USASA Co (2)	Ft Hancock (4)
CC-E (7)	182nd USASA Co (2)	Ft Gordon (10)
Dir of Tram (1)	183rd USASA Co (2)	Ft Huachuca (10)
CofEngrs (1)	184th USASA Co (2)	Ft Carson (21)
TSG (1)	251st USASA Co (2)	Ft Knox (12)
CofSptS (1)	102nd USASA Det (2)	Ft Ritchie (5)
USAAESWBD (5)	104th USASA Det (2)	WSMR (5)
USAAVNTBD (5)	Svc Colleges (2)	WRAMC (1)
USACDCEA (1)	Br Svc Sch (2) except	USAERDAA (2)
USACDCCBRA (1)	USATSCH (5)	USAERDAW (13)
USACDCCEA (1)	USA Tng Cen & Sch (5)	USACRREL (2)
USACDCCEA:	Sig FLDMS (2)	USARSG (5)
Ft Huachuca (1)	AMS (1)	Units org under fol TOE:
USACDCOA (1)	USMA (5)	(2 copies each)
USACDCQMA (1)	GENDEP (2)	11-6
USACDCTA (1)	Sig Sec GENDEP (5)	11-35
USACDCADA (1)	Sig Dep (12)	11-37
USACDCARMA (1)	A Dep (2) except	11-38
USACDCAVNA (1)	LBAD (14)	11-39
USACDCARYTA (1)	SAAD (30)	11-56
USACDCSWA (1)	TOAD (14)	11-57
USAMC (5)	FTWOAD (10)	11-97
USCONARC (5)	LEAD (7)	11-98
ARADCOM (5)	SHAD (3)	11-117
ARADCOM Rgn (2)	NAAD (5)	11-155
OS Maj Comd (4)	SVAD (5)	11-156
LOGCOMD (2)	CHAD (3)	11-157
USAMICOM (4)	ATAD (10)	11-158
USASMC (2)	SEAD (7)	11-225
USASCC (4)	USASTC (2)	11-226
MDW (1)	USATC Armor (2)	11-358
Armies (2)	USATC Engr @	11-500 (AA-AC)
Corps (2)	USATC Inf (2)	11-587
USAC (3)	Army Pic Cen (2)	11-592
507th USASA Gp (2)	USACDCEC (10)	11-597
508th USASA Gp (2)	USATTC (5)	29-56
318th USASA Bn (2)	USAJFKCENSPWAR (5)	29-134
319th USASA Bn (2)	Instl (2) except	

NG: State AG (3).

USAR: None.

For explanation of abbreviations used, see AR 320-50.

RECOMMENDED CHANGES TO EQUIPMENT TECHNICAL PUBLICATIONS



THEN...JOT DOWN THE DOPE ABOUT IT ON THIS FORM. CAREFULLY TEAR IT OUT, FOLD IT AND DROP IT IN THE MAIL.

SOMETHING WRONG WITH PUBLICATION

FROM: (PRINT YOUR UNIT'S COMPLETE ADDRESS)

DATE SENT

PUBLICATION NUMBER

PUBLICATION DATE

PUBLICATION TITLE

BE EXACT PIN-POINT WHERE IT IS

PAGE NO.

PARA-GRAPH

FIGURE NO.

TABLE NO.

IN THIS SPACE, TELL WHAT IS WRONG AND WHAT SHOULD BE DONE ABOUT IT.

TEAR ALONG PERFORATED LINE

PRINTED NAME, GRADE OR TITLE AND TELEPHONE NUMBER

SIGN HERE

